

---

## C-21 Live Steam



---

**ACCUCRAFT TRAINS**  
33268 Central Avenue  
Union City, CA 94587  
Tel: 510 324-3399  
Fax: 510 324-3366  
email: [info@accucraft.com](mailto:info@accucraft.com)



# INSTRUCTION MANUAL

---

---

## General Information - C-21 Live Steam



### ***Introduction***

The C-21 was a mid sized outside frame locomotive that worked on the Denver & Rio Grande Western Railroad. The two locomotives #360 and #361 were rebuilds done in 1924 and were retired in the mid 1950's. These two locomotives were almost identical except for minor detail differences. The placement of the headlight and the size of the air tank on the tender are two of the most noticeable detail differences on the models. These outside frame consolidations are excellent prototypes for a live steam model. They are heavy, have small drives and a large boiler. This results in good pulling power and long running time. Both of these models from Accucraft are identical in their function and operation.

Operating a live-steam locomotive is much different from running an electrically powered engine. It is a more hands-on, interactive experience. The locomotive must be periodically fueled, oiled, and watered. As supplied, the C-21 is manually controlled, which means that you must actually drive the locomotive using the controls in the cab, just as you would a full-size engine.

The performance of the engine is also unlike electric locomotives. The C-21 should pull up to a dozen standard-size freight cars on good, level track. Grades and sharp curves will diminish its capability. A good engineer will learn the engine's characteristics and idiosyncrasies over time, to get the best performance and longest duration from it.

### ***Technical Specification***

Scale/Gauge: 1/20.3, 45 mm Gauge  
Wheel arrangement: 2-8-0 Consolidation

Total Weight: 8.2 Kg, 18 lbs.  
Length: 838 mm, 33 ins.  
Width: 146 mm, 5.75 ins.  
Height: 182 mm, 7.5 ins.

Driver Wheels: Dia. 45 mm, 1.8 ins.  
Minimum Radius: 1.9 M, 48 ins.

Boiler: Center flue type  
Working Pressure: 40 psi  
Fuel: Butane

Lubricator: Displacement Type  
Valve gear: Simple Stephenson

---

## Safety - C-21 Live Steam



### **Safety**

For your safety, there are certain rules that should be observed, as follows:

1. The safety valve is under the steam dome (the dome nearest the cab). It has been set at the factory to release at 40 pounds per square inch of pressure. Never tamper with the safety valve.
2. The firing system has been designed to use butane gas only. Never use any other gas (including propane or butane/propane mix), as the storage pressures can reach unsafe levels.
3. Always refuel the engine away from other working live-steam locomotives. The fuel filling system allows a small amount of the gas to bleed off as the fuel tank is being filled. A passing engine can ignite this bleed-off gas, causing a potentially hazardous situation.
4. When lighting up, light your match first, then turn on the gas.
5. A steam engine gets hot. Be careful.

### ***The following parts are packaged separately***

- M3 hex head screws
- 3mm hex head screw driver
- 5 ml syringe - steam oil
- 50 ml syringe - water

### ***Caution!***

This model is an accurate replica of the original locomotive. It has sharp and moving parts. The locomotive drive rods are stainless steel with sharp edges. **AT ANY TIME, OPERATORS MUST NOT BECOME IN CONTACT WITH THE MODEL WHILE IT IS POWERED. UNDER NO CIRCUMSTANCES SHALL ACCUCRAFT TRAINS BE RESPONSIBLE FOR ANY INCIDENTAL OR CONSEQUENTIAL DAMAGES ARISING IN REGARD TO ANY ACCUCRAFT PRODUCT.**



---

## Operation - C-21 Live Steam



### *Preparing the engine*

A steam-locomotive engineer goes through a lighting-up ritual every time the engine is to be run. It is good to follow the same routine each time so that nothing is overlooked.

1. Oil all external moving parts, including wheel bearings, of the engine and tender with a high grade, lightweight machine oil like 3-in-1.

2. Place the engine and tender on the track and couple them together. The drawbar between the units has two holes. For tighter curves, use the outer hole. For wide-radius curves, the engine and tender can be coupled more closely together, using the inner hole. Insert the gas jet (at the end of the hose coming from the tender) into the back of the burner. Make sure it seats snugly.

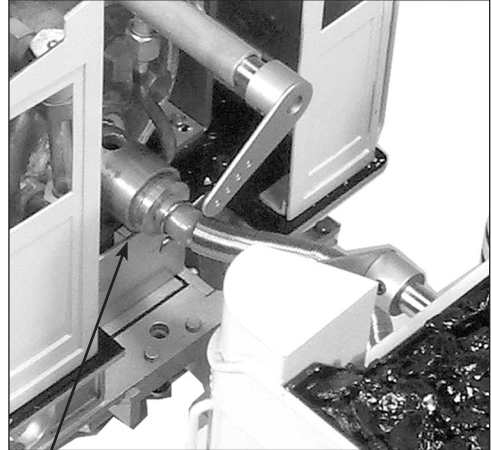

The gas jet is inserted into the back of burner.

3. The displacement lubricator is in the cab. This lubricator ensures the cylinders and valves are properly lubricated inside. As the steam passes through it, a small amount will condense into water. This water will sink to the bottom of the lubricator, forcing a similar quantity of oil into the steam line and thus to the cylinders. Remove the lubricator's cap and draw out any water from the previous run with a syringe or blow down the lubricator when the engine has steam pressure on the gauge. To do this, simply open the throttle a little and then open the small valve under the lubricator. The water will blow out the bottom and when oil starts to drain out, shut the small valve. Shut the throttle, open the lubricator cap and refill with steam cylinder oil.

---

## Operation - C-21 Live Steam



4. Unscrew the filler plug and fill the boiler to the top of the glass with water. Use only distilled water in your engine's boiler. Tap water contains minerals that will leach out and ultimately affect the performance of the engine.

5. Finally, add fuel. Your C-21 burns butane gas. The gas tank is located in the tender beneath the dummy coal load. Remove the coal load with the ring provided. Butane gas can be purchased at the grocery store or at a tobacconist's as cigarette-lighter refills. These come with a nipple suitable for the filler valve on the C-21's gas tank. (Butane can also be purchased in larger containers at camping-supply stores, but these cans will require a special adapter for filling the engine's tank.) Simply press the nozzle of the butane canister hard onto the

filler valve atop the tank, making sure that the control valve is closed. You will hear the gas transferring and will see a little gas bleeding out of the valve. When the tank is full, the gas will begin to splutter and much more gas will escape the valve. When the gas tank is full you are ready to fire up the engine.

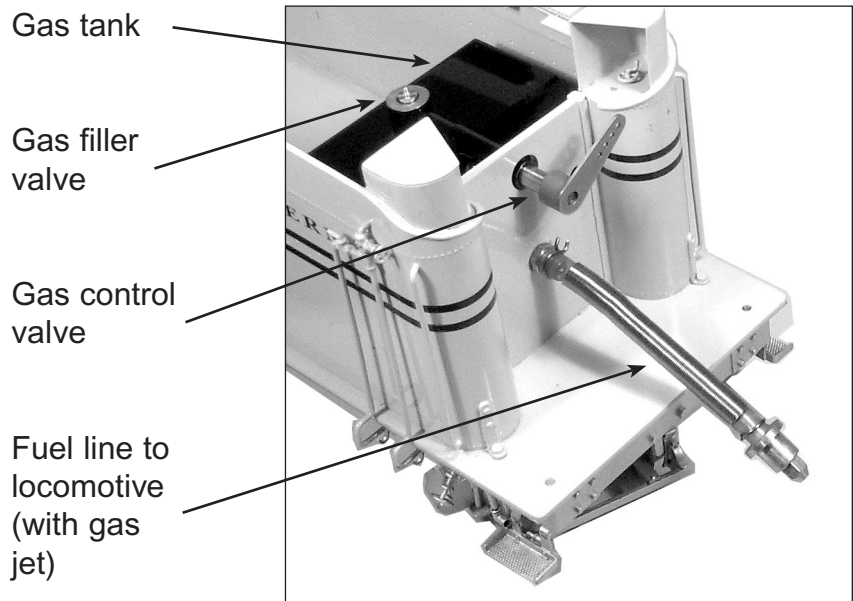

---

## Operation - C-21 Live Steam



### *Firing up*

Before igniting the fire, open the blowdown valve. You'll find this below the cab on the left side. It isn't necessary to open the valve all the way—a turn or two is all that's required. Make sure the throttle is closed.

The engine's burner resides at the back of the flue inside the boiler. Open the hinged smokebox door at the front of the engine and you'll be able to see the flue. To light up, strike a match and hold it at the open smokebox door while simultaneously opening the gas valve in the tender very slowly until the gas ignites. You should hear the gas coming into the burner. Opening the valve too wide or too fast may blow out the flame or cause the fire to burn in the smokebox. The fire should flash back into the back of the flue with a quiet "pop." If it wants to burn in the

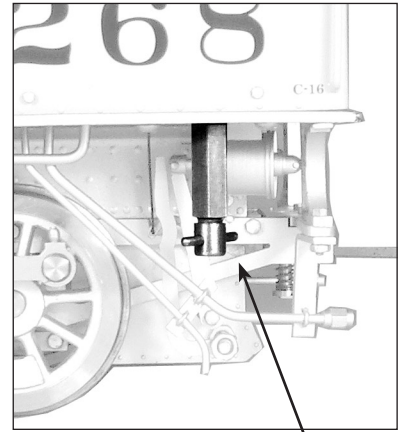

Blowdown

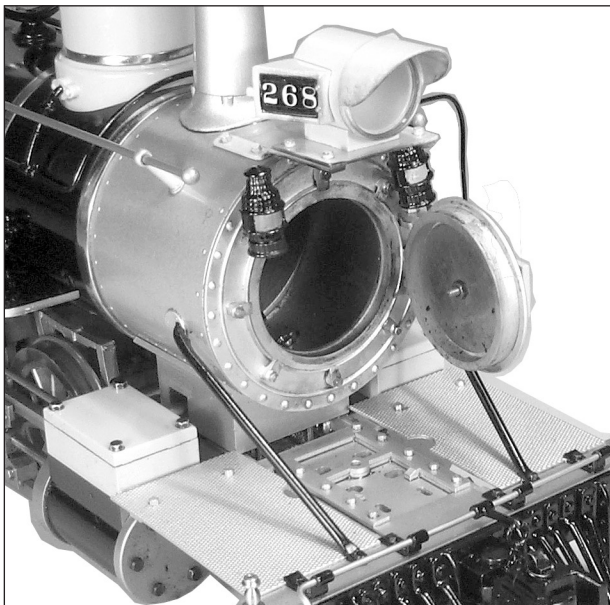

smokebox or in the forward part of the flue, slowly close the gas valve until it flashes back to the burner. Don't let the fire burn in the smokebox—your engine will not run as it should and may be damaged. The fire should burn under the burner in a crescent-shaped flame, which should be clearly visible through the smokebox door. The flame should be bright blue and should burn steadily. If it sputters or looks yellow or green, adjust the gas valve accordingly. The object is to run the burner at the lowest setting possible to operate the engine, thereby increasing the efficiency of the engine and the duration of the run. You'll get the hang of this with practice.

As the engine heats up, water will begin to come out of the blowdown valve. Keep an eye on this. After four or five minutes, the escaping water will turn to steam. At this time, close the valve. The water in the water glass should be just below the top nut.

After another four or five minutes, pressure on the pressure gauge should read about 20psi (pounds per square inch) or so. The safety valve is set at 40 psi. When the pressure on the gauge reaches 40psi, the engine can be run.

---

## Operation - C-21 Live Steam



### ***Running***

Slide the cab roof off (toward the rear) for access to the controls. Move the reversing lever at the right side of the cab to the forward position. With the engine on the track, and without a train, open the throttle. Because the cylinders are cold, the hot steam entering them will condense into water and be exhausted through the stack. The engine may need to be pushed a little to overcome the steam condensing into water in the cold cylinders. After a few moments, it should take off on its own, moving away smoothly.

Once the engine is running smoothly, a train can be coupled on and the run can proceed. Since all of the locomotive's functions are controlled from the cab, it can be driven like a full-size engine, meaning that you'll have to stay with the engine through the run if you want to change its speed or direction. If you have a suitable track, the engine can be left to run on its own at a steady speed. Keep your eye on the water glass. When the water level approaches the bottom of the glass, shut the engine down and repeat the firing up process.

Reversing lever

Pressure gauge

Throttle

Water glass

Burner

Drawbar

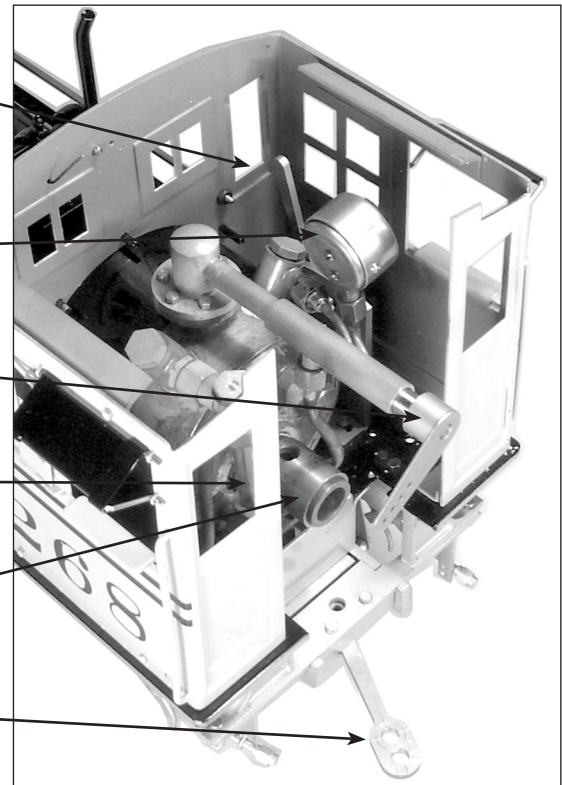

### ***Shutting down***

To shut the engine down, simply close the gas valve and allow the engine to run off any residual steam. At the end of the run, open the blowdown valve and leave it open. This will relieve the boiler of what little pressure remains and prevent a vacuum from forming inside the boiler that could draw lubricating oil into the boiler if the throttle valve is not fully closed.

After a day's operation in the garden you'll probably find that your engine has a coating of oil all over it. This is steam-cylinder oil that has been exhausted from the stack. A simple wipe down with a dry cloth is all that's necessary to restore the engine to pristine condition. This is best done while the engine is still hot. Wipe any grit and excess oil from the wheels and running gear.

---

## Operation - C-21 Live Steam



The boiler can be drained of water, or not, as you will. Leaving water in the boiler will not harm it. The lubricator can also be drained and refilled with steam oil in preparation for the next run.

### ***Cold-weather running***

The weather can dramatically affect the performance of your locomotive. Cold and wind can decrease efficiency to a disappointing level. Butane gas becomes liquid at 32°F and will not work. As it approaches 32°, its pressure becomes less and less.

The tender tank is divided into two compartments. The rear compartment is to be left empty. The forward compartment contains the fuel tank, and this can be filled with warm water in cooler weather. This will warm the gas in the tank and keep its pressure up, which will cause the engine to operate in a much more lively manner, much as it does in warm weather. If the water in the tank cools, just replace it with warmer water. Empty the tender at the end of the day's run. Note: the temperature of the fuel-supply can must always be higher than that of the engine's gas tank. If you have warmed the engine's tank and the supply tank is cooler, gas will not transfer. (If you have installed the optional hand pump, the forward tank is also to be used to carry boiler feedwater.)

### ***Notes on radio control***

Although the C-21 was designed as a manually controlled locomotive, there is no reason why radio control (R/C) cannot be fitted, with some ingenuity. A two channel radio is all that's necessary, one for the throttle and one for the reversing lever. The gas valve should always be controlled manually. The reversing lever will have to be modified so that it does not lock in position, but it must still have stops at either end of its throw for proper positioning of the reversing valve.





# Parts & Accessories - C21 Live Steam

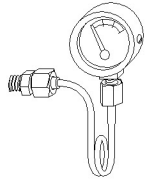

- AP21151
- Boiler pressure gauge w/ fitting
- 1/pkg



- AP21351
- Jet Nozzle 0.15mm
- AP21352
- Jet Nozzle 0.20mm



- AP28201
- Steam oil, 6 oz
- 1bottle/pkg

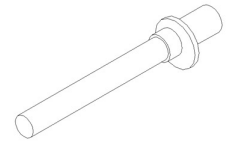

- AP21301
- Burner
- 1/pkg



- AP19001
- Treadmill roller
- 1/pkg



- AP11730
- Knockle couplers
- 1pair/pkg



- AP29101
- Screw driver, hex M2



- AP29201
- Steam oil pump
- 1/pkg

- AP29102
- Screw driver, hex M1.6

## Hex head screws:

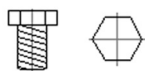

- AP25002 M2x2 8/pkg
- AP25003 M2x3 8/pkg
- AP25004 M2x4 8/pkg
- AP25005 M2x6 8/pkg
- AP25006 M2x8 8/pkg

## Set screws:

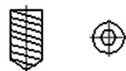

- AP25101 M3x3 8/pkg
- AP25102 M3x6 8/pkg

## "O" Rings:



- AP25802 Oil Lub. 4/pkg
- AP25804 Butane valve 4/pkg
- AP25805 Steam valve 4/pkg